



JOB NAME:	CONTRACTOR:
JOB LOCATION:	APPROVAL:
ENGINEER:	CONTRACTOR P.O.:
APPROVAL:	REPRESENTATIVE:

8E720289-00*

720289 2-WAY CARBON STEEL, ANSI 300 FLANGED, WAFER STYLE, FULL PORT BALL VALVE WITH VALBIA ELECTRIC ACTUATOR AND BRACKET

SIZES 1/2" TO 6"

*001	12V AC/DC	*002	24V AC/DC	*003	100-240V AC
01	BATTERY BACKUP	*02*	POSITIONER	*04*	BATTERY BACKUP W POSITIONER

SPECIFICATIONS

The Bonomi 8E720289 series electric package features the 720289-carbon steel, short pattern, wafer full port, ANSI 300 flanged ball valve, in sizes 1/2"-6".

This space saving valve also meets ANSI 16.34, ANSI 16.5, NACE MR 0175/ISO 15156 and NACE MR 0103. It has RTFE seats, and a combination PTFE and Viton dual stem packing design.

The Valbia VB series actuator housing is made from a high impact resistant technopolymer, and standardly features dual motors, two extra limit switches, a heater & thermostat, a torque limiter, dual ISO patterns, female star drive, position indicator, PG11 connections, and a 75% duty cycle motor. The actuator is also NEMA 4,4X rated. Options include positioning boards, battery backups, or a combination of the two.

ACTUATOR FEATURES

- NEMA 4, 4X IP67 Housing
- 12V/24V AC/DC and 100-240V AC Models Available
- ISO 5211 dual patterns
- VB015 -12/24V AC - 50% Duty Cycle
- VB030-VB110 - 12/24V DC and 100-240V AC - 75% Duty Cycle
- High-Strength, Impact Resistant IP67 Technopolymer Housing
- Heater & Thermostat
- Torque Limiter
- Temperature Range -4°F to 131°F
- PG11 Electrical Connection/Optional 1/2" Conduit

VALVE FEATURES

- Carbon steel, ANSI class 300 flanged
- Full port, sizes 1/2" to 6"
- Temperature range -4°F to 400°F
- Blow-out proof stem
- R.P.T.F.E. seats, packing and thrust washer
- Space saving design
- 100% tested
- TUV T.A. Luft approved
- ANSI B16.34 design
- ISO 5211 mounting pad with double "D" stem

PRESSURE - TEMPERATURE CHART FOR SERIES 720289

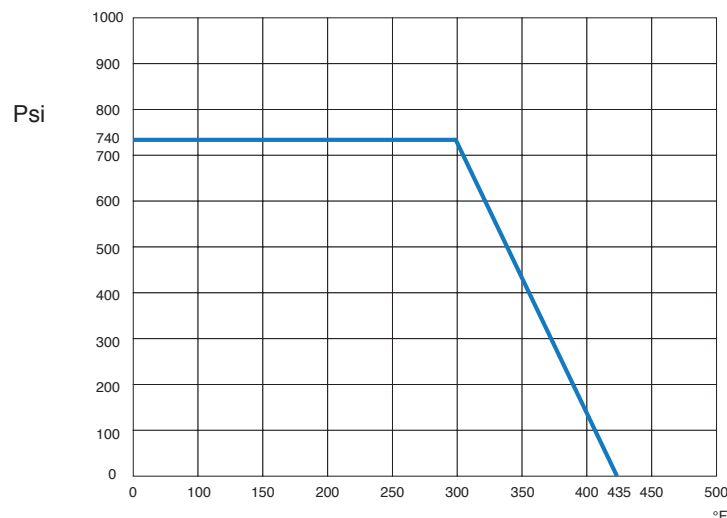

BILL OF MATERIALS FOR 720289

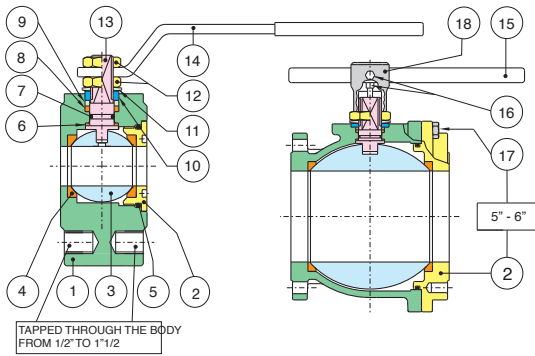

N POS	PART NAME	MATERIAL	N PCS
1	BODY	ASTM A105/WCB	1
2	END CONNECTION	ASTM A105/WCB	1
3	BALL	A479-304/A351 CF8M	1
4	BALL SEATS	R.P.T.F.E.	2
5	O-RING	FKM (Viton®)	1
6	THRUST WASHER	P.T.F.E.	1
7	RING	FKM (Viton®)	1
8	STEM SEAL	P.T.F.E.	1
9	PACKING GLAND	STEEL	1
10	END STOP	STEEL	2-1

N POS	PART NAME	MATERIAL	N PCS
11	SPRING WASHER	STEEL	2
12	NUT	STEEL	2
13	STEM	AISI 304	1
14	HANDLE	STEEL	1
15	HANDLE DN 150-200	STEEL	1
16	SCREW	STEEL	2
17	SCREW	STEEL	12
18	BODY HANDLE DN150-200	CAST IRON	1
19	UNSCREWING GROWER	A182-F316	1

DIMENSIONS

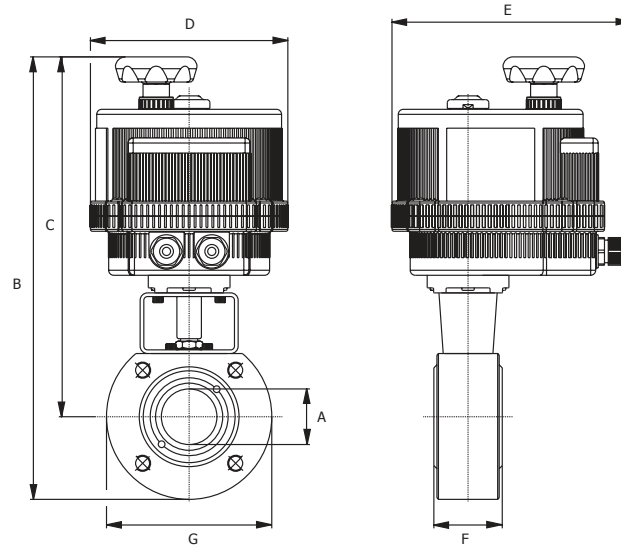

Size	1/2"	3/4"	1"	1-1/4"	1-1/2"	2"	2-1/2"	3"	4"	6"
A	.500	.750	1.00	1.25	1.50	2.00	2.50	3.00	4.00	6.00
B	10.5	10.9	13.1	13.8	15.7	16.2	17.9	18.6	20.6	22.1
C	8.81	8.97	11.0	11.2	12.9	13.2	14.5	14.9	16.3	17.2
D	4.84	4.84	6.18	6.18	7.28	7.28	8.30	8.30	8.30	8.30
E	6.45	6.45	7.51	7.51	8.46	8.46	9.33	9.33	9.33	9.33
F	1.37	1.57	1.81	2.12	2.51	3.22	4.05	4.80	5.98	7.71
G	3.54	3.93	4.33	5.11	5.51	5.90	6.88	7.48	8.66	9.84
Act.	VB015	VB015	VB030	VB030	VB060	VB060	VB110	VB110	VB190	VB190

ON/OFF WIRING DIAGRAM - VB030 -VB190

12V AC/DC, 24V AC/DC & 100-240VAC

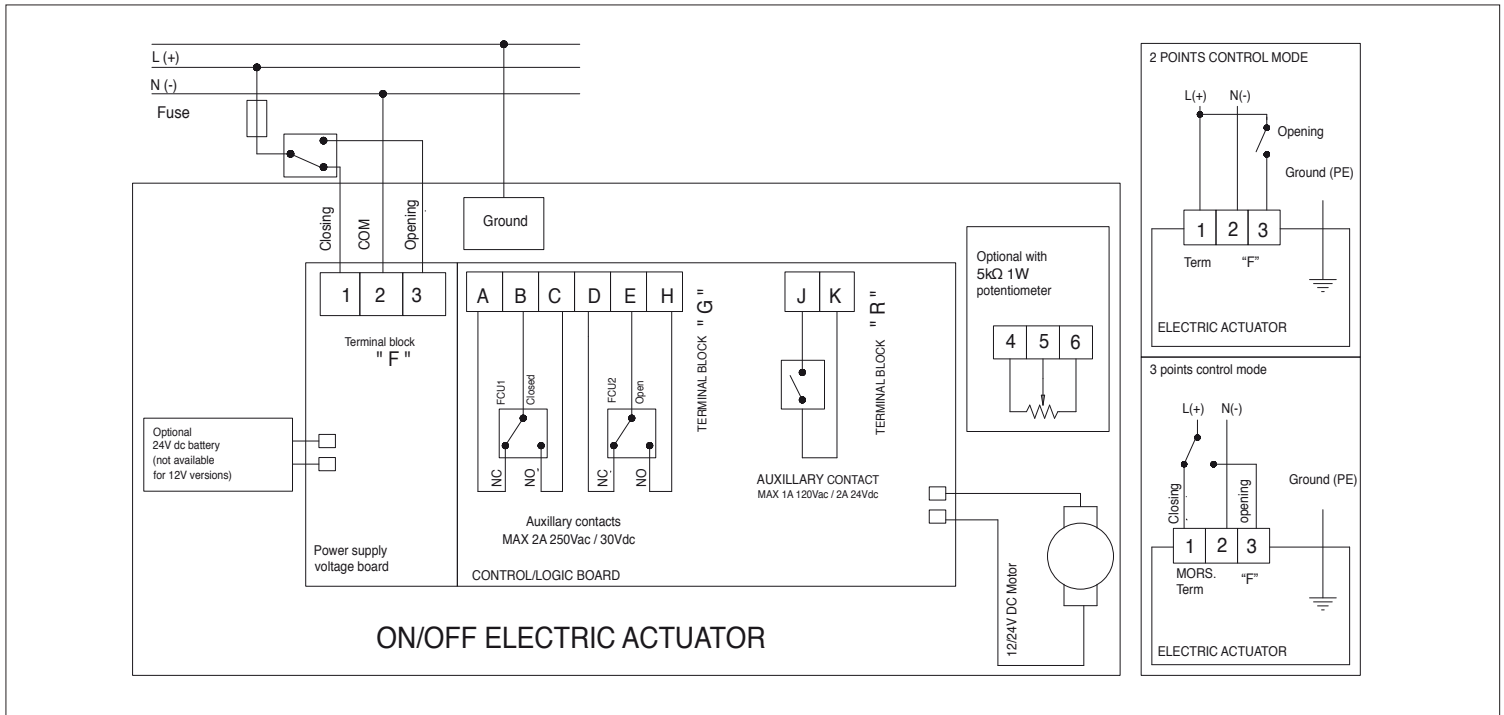

POSITIONER WIRING DIAGRAM - VB030 -VB190

12V AC/DC, 24V AC/DC & 100-240VAC

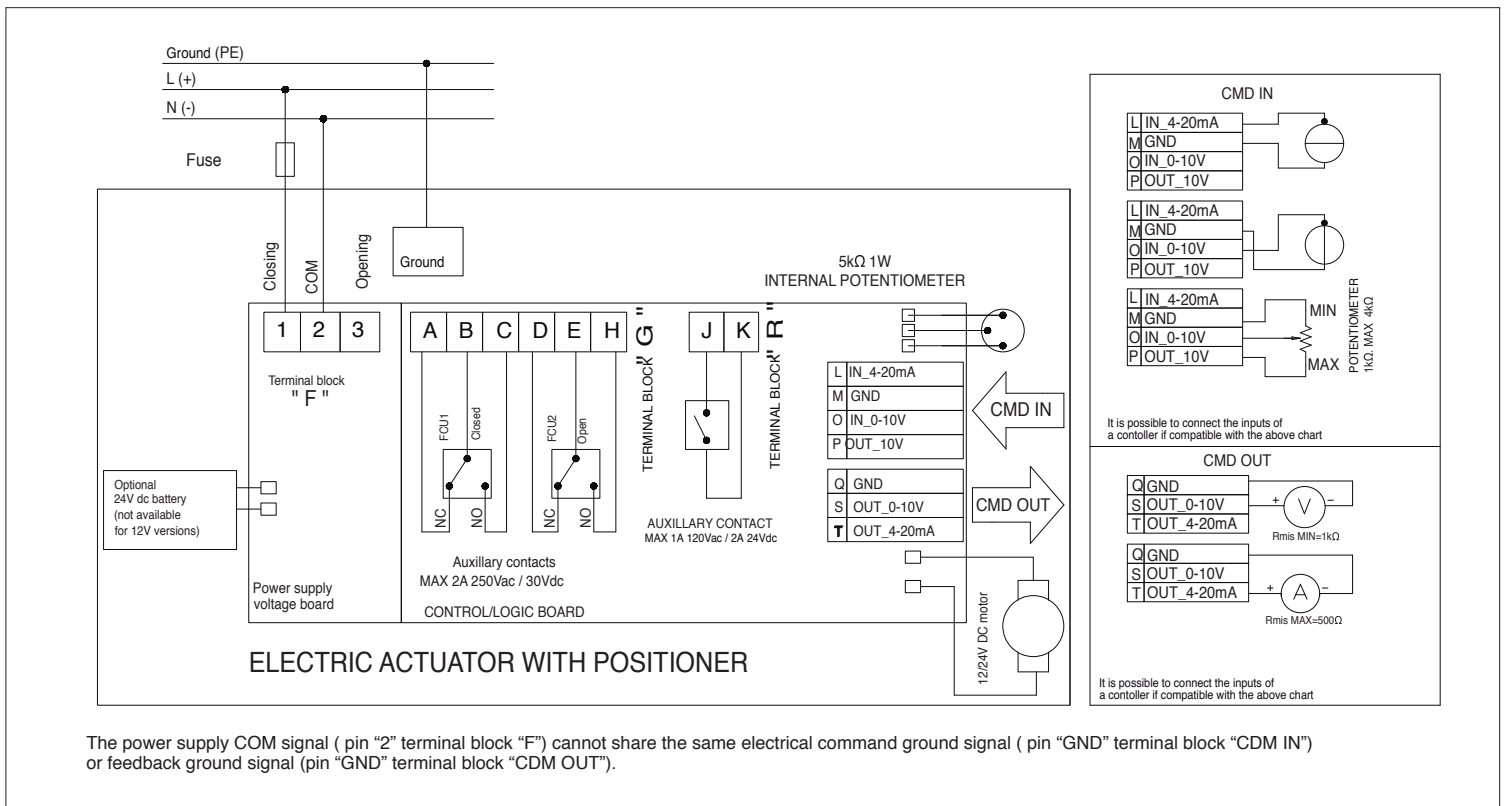

The power supply COM signal (pin "2" terminal block "F") cannot share the same electrical command ground signal (pin "GND" terminal block "CDM IN") or feedback ground signal (pin "GND" terminal block "CDM OUT").